



WALL BRACKETS - Popular or Clothesmaid models

FIG 1.

Our Wall Brackets should fix into a load bearing structure. A solid masonry wall ideally. We don't advise fixing to stud walls unless noggins or suitable fixings can be used.

If in doubt consult your builder/handyman.

What's included:

Each bracket is designed for maximum height up a wall. They come with the pulleys already fitted. They have 4 screw holes to ensure they are firmly fixed to the wall.



FIG 2.

Choose a position for the airer. Can you raise and lower the clothesmaid without obstruction? Is the fixing position for the cleat in line with the pulley position and into a solid structure? Do not suspend your airer above or near any heat source that could result in a fire.

Mark out the spacings for the Wall Brackets using the pulley positions:

- 0.7m apart for the 0.9m airer
- 1.0m apart for the 1.2m airer
- 1.2m apart for the 1.5m airer
- 1.4m apart for the 1.8m airer
- 1.6m apart for the 2.0m airer

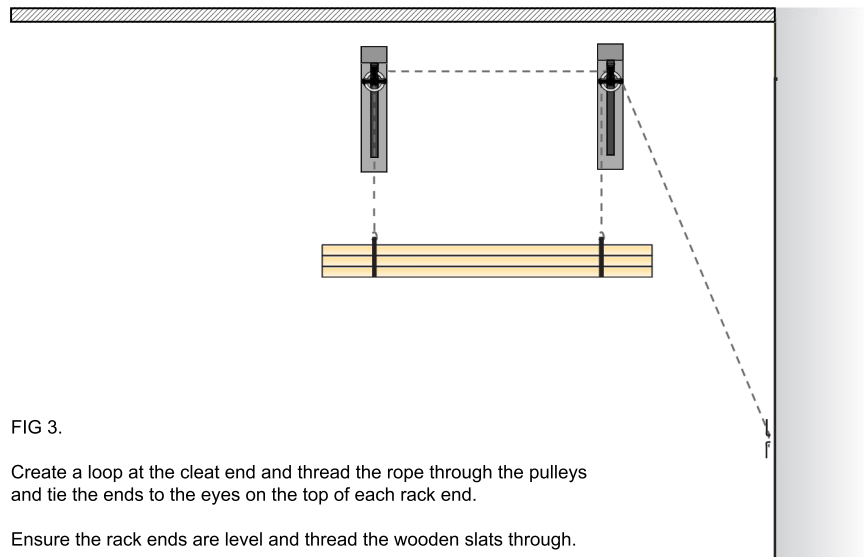

FIG 3.

Create a loop at the cleat end and thread the rope through the pulleys and tie the ends to the eyes on the top of each rack end.

Ensure the rack ends are level and thread the wooden slats through.

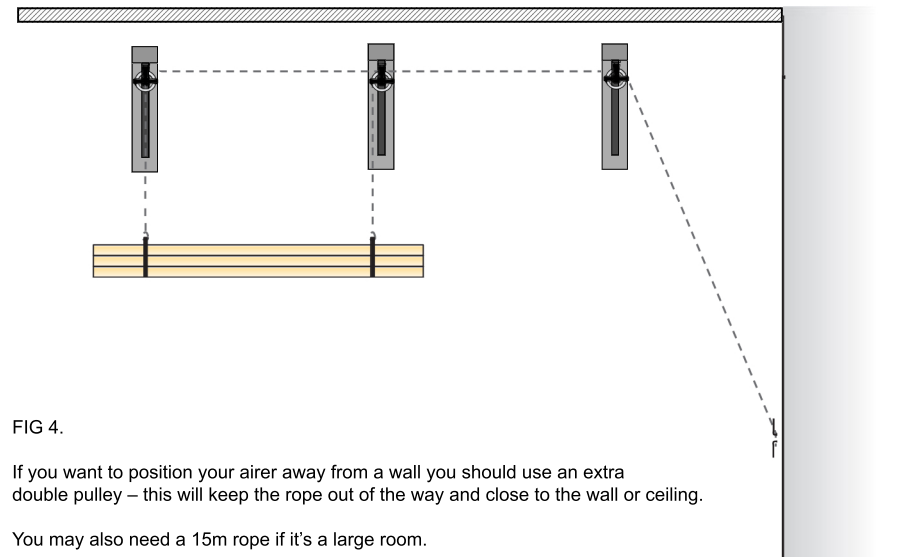

FIG 4.

If you want to position your airer away from a wall you should use an extra double pulley – this will keep the rope out of the way and close to the wall or ceiling.

You may also need a 15m rope if it's a large room.